

Received June 5, 2020, accepted August 3, 2020, date of publication August 10, 2020, date of current version August 21, 2020.

Digital Object Identifier 10.1109/ACCESS.2020.3015202

Pulsar Based Alternative Timing Source for Grid Synchronization and Operation

HE YIN¹, (Member, IEEE), YILU LIU^{1,2}, (Fellow, IEEE),
PETER L. FUHR², (Senior Member, IEEE), MARISSA MORALES RODRIGUEZ², (Member, IEEE),
MARGARET MORGANTI², (Associate Member, IEEE), WILLIAM MONDAY²,
JASON RICHARDS², AND STERLING SEAN ROOKE¹

¹Department of Electrical Engineering and Computer Science, University of Tennessee, Knoxville, TN 37996, USA

²Oak Ridge National Laboratory, Oak Ridge, TN 37831, USA

Corresponding author: Peter L. Fuhr (fuhrpl@ornl.gov)

This work was supported in part by the National Science Foundation (NSF) under Award EEC-1920025, in part by the Department of Energy, in part by the Engineering Research Center through the Engineering Research Center Program of the National Science Foundation, in part by the Department of Energy NSF under Award EEC-1041877, and in part by the Center for Ultra-Wide-Area Resilient Electric Energy Transmission Networks Industry Partnership Program.

ABSTRACT The need for timing sources that are alternatives to GPS has been under consideration for years. The reliance of power systems instrumentation and control systems on GPS timing serves as the basis for the study reported in this paper. The issues associated with grid timing requirements are reviewed within the context of a GPS-based clock source. Of principle investigation is the possibility of using millisecond rotation neutron stars, pulsars, as the alternative time source. A design of an instrument (referred to as a pulsar based timing instrument, PBTI) that would use stable and accurate pulsar signals for grid timing is presented. The described PBTI design has been logically separated into software and hardware segments. Flexible signal processing is performed in software which will transfer the raw pulse data from the pulsars into a pulse per second (PPS) signal which can be directly utilized in the power system components and applications. The hardware aspects of the PBTI design concentrate on the antenna requirements, with specific concern associated with the required size and pointing/tracking needs, back-end, filters, amplifiers, and signal generator design. An overall block diagram and the detailed descriptions of both the software and hardware designs are presented. Finally, the potential future applications and problems of the pulsar based timing instrument are discussed.

INDEX TERMS Millisecond rotation pulsars, GPS alternative timing, power system monitoring.

I. INTRODUCTION

Precision timing is of key importance in the operation of the electric grid. IEEE/IEC standard, part 118-1 of C37, stipulates that the electric grid relays and protection equipment operate with total vector error (TVE) of synchronized phasor (synchrophasor) measurements of less than 1% [1]. In addition, the accuracy for a power grid operating frequency is also critical. As shown in Fig. 1, the frequency responses recorded by phasor measurement units (PMUs) under a common power system event are given. It can be clearly observed that the accuracy of the frequency measurement is critical for power system applications such as event detection. In order to achieve this level of accuracy, a precise time synchronization

The associate editor coordinating the review of this manuscript and approving it for publication was Zhouyang Ren¹.

signal is essential for power system monitoring and measurement - a task that is being performed by PMUs. The vast majority of deployed measurement systems rely on a Global Positioning Systems (GPS) timing signal (or pulse) with time accuracy better than 100 ns in theory via pulse per second (PPS) signals [2]. Sharing a uniform time reference, a PPS output enables all the PMUs across a wide geographical area to synchronize their clocks. Specifically, by demodulating the GPS signal, GPS receivers within PMUs can align their time with GPS-provided time and then output a high-precision PPS signal for waveform sampling. Such waveform sampling by analog to digital converters in PMUs begin triggered by PPSs ensures that the first sample in each second is synchronized and temporally aligned to the PPS. In such a scenario, the stability and precision of PPS signals from GPS receivers are the prerequisite of accurate waveform sampling and

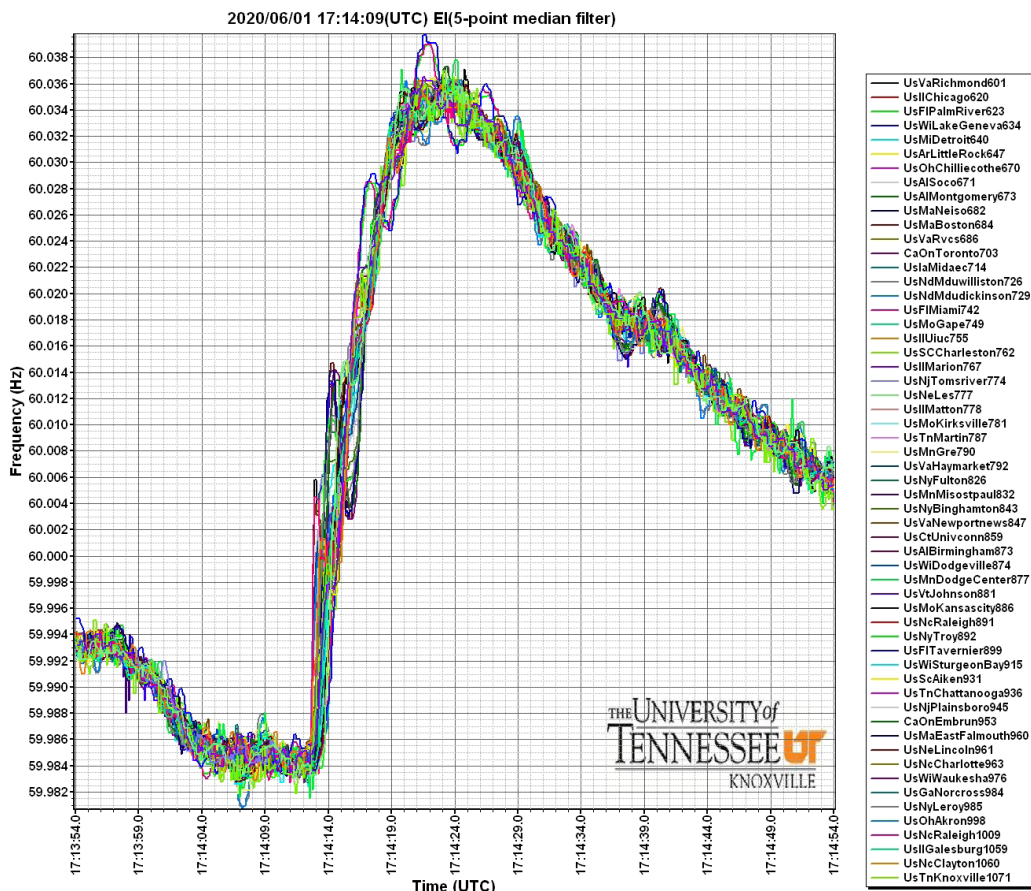

FIGURE 1. Frequencies recorded by PMUs under a power system event.

synchronized measurements in power systems. An issue arises for GPS signals are vulnerable to a number of disruptions and distortions. One such interruption set arises from potential interference caused by space weather conditions, especially solar activities. Such occurrences are hardly academic, for example the satellite SVN23 induced a 13 second GPS timing error on Jan. 26, 2016 [3], which did not, but may have resulted in serious impacts across electric power grids due to the PMUs reliance on GPS. The preponderance of GPS jamming/spoofing devices and Internet-accessible “build manuals” for such device makes targeting and interruption of PMUs operation relatively easy.

In this paper, the concept of using pulsars as an alternative-to-GPS timing source is described. A first level design of a pulsar-timing-instrument to be designed is presented.

Alternative Source – Pulsars: Pulsars are compact, highly-magnetized rotating neutron stars radiating with an emission pattern similar to a dipole. The analogy of such a rotating “beacon” to that of a lighthouse beacon is accurate. Detection of such a rotating source allows for measurement of the temporal stability of the radiated beacon (signal), as shown in Fig. 2. Such measurements have revealed that pulsar

rotation periods (generally) range between one millisecond and one second with a nominal deviation of less than 10^{-15} seconds per second. In certain cases, pulsars with a rotation variation of less than 10^{-18} seconds have been observed [4]–[7]. Hence the pulsar functions as a highly stable and repeatable signal source. In addition, pulsars have long-term stability that extends to millions of years, considerably longer than terrestrial atomic clocks [6], [7]. While the study of pulsars originally focused on the astrodynamics associated with the origin and operating principles of such a star, the recognition of multiple highly stable “clock sources” distributed throughout the observable universe led to the concept of basing a navigation system on such sources. In the case of measuring pulsar X-ray emission, NASA’s Station Explorer for X-ray Timing and Navigation Technology (SEXTANT) mission, involved demonstrating real-time on-board X-ray Pulsar Navigation [8]. In astrophysics, a Pulsar Timing Array (PTA) was designed to detect and analyze variations in the arrival times of pulsar generated signals which may be caused by gravitational waves [9]–[11].

An alternative to such astronomical, astrodynamics and space-based navigation “uses” of pulsar signals, involves

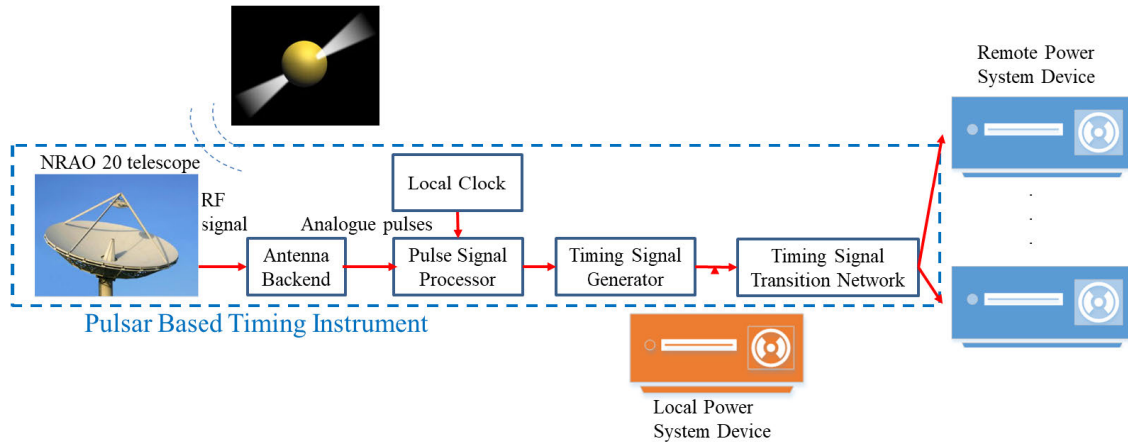

FIGURE 2. The hardware architecture of the PBTI.

the use of pulsar signals as a precise timing source. The specific application investigated involves the potential use as an alternative to GPS signals in electric grid applications [12]. With an immediate application based in coordinated wide-area monitoring and control signaling, we developed a pulsar-based timing instrument (PBTI). The PBTI system is currently in the design, continual development and enhancement phase.

Design details and the overarching architecture, both hardware and software, including subfunctions utilized in the pulse signal processor are presented in the following sections. Finally, four possible applications of the PBTI are discussed along with envisioned benefits associated with PBTI utilization, as compared to a GPS-based system.

II. THE HARDWARE ARCHITECTURE OF THE PULSAR BASED TIMING INSTRUMENT

As shown in Fig. 2, the hardware architecture of the pulsar based timing instrument is presented. It can be observed that the PBTI consists of six sub-function units: (1) the radio telescope, (2) the antenna back-end, (3) the local clock, (4) the pulse signal processor, (5) the timing signal generator, and (6) the timing signal transmission network. Note that the architecture for the PBTI basically follows the architecture for a traditional radio telescope with a goal of allowing the PBTI to utilize elements (or entirety) of a traditional radio telescope system. Some additional modules for both hardware and software are added to realize the timing signal generation function.

Of key concern to the overall concept is the selection and installation of a radio telescope pointed at the correct location and receiving a usable pulsar signal. Note that the radio telescope should be able to receive the radio emission from a pulsar and be flexible to install the PBTI’s backend. Consider the three radio telescope designs highlighted in Table 1. The Arecibo and Green Bank radio telescopes represent very large, single aperture devices. The third listed single

TABLE 1. Radio telescopes tested in this research.

Radio Telescope Name	Location	Size (diameter)
William E. Gordon Telescope	Puerto Rico, US	305 m
Robert C. Byrd Green Bank Telescope	West Virginia, US	100 m
NRAO20	West Virginia, US	20 m

aperture telescope is a 20m in diameter located in the green bank observatory. Initial calculations of receiver sensitivity and antenna gain suggest that this commercially available telescope (antenna) yields a signal-to-noise ratio (SNR) that should allow for the detection of received pulsar signals with accompanying generation of a usable RF signal. This signal is, in turn, used by subsequent subfunctions. Currently, the research team has received a 3 hour millisecond pulsar data recorded from the radio telescope, NRAO20 [13]. The team is working on a detailed feasibility analysis utilizing the NRAO20 as the radio telescope for the PBTI. The detailed description of the NRAO20 radio telescope can be found in [13]. Note that the millisecond rotation pulsar identification and selection – a critical component of the research investigation. The current conclusion is try to test the PBTI with pulsar J1713+0747 using the NRAO20 green bank observatory. Another concern is the pulsar selection. The PBTI requires a stable and highly precise pulsar period upon which the timing signal is based. Although an initial inspection suggests that a millisecond pulsar can satisfy the requirements for timing signals, it also requires a large antenna and low SNR for the environment. There are some “canonical” pulsars which have the potentiality to provide stable and highly precise timing signals. Further investigation into this pulsar source type is warranted.

The second sub-function unit of the PBTI is the antenna back-end which is utilized to sample the RF or potentially

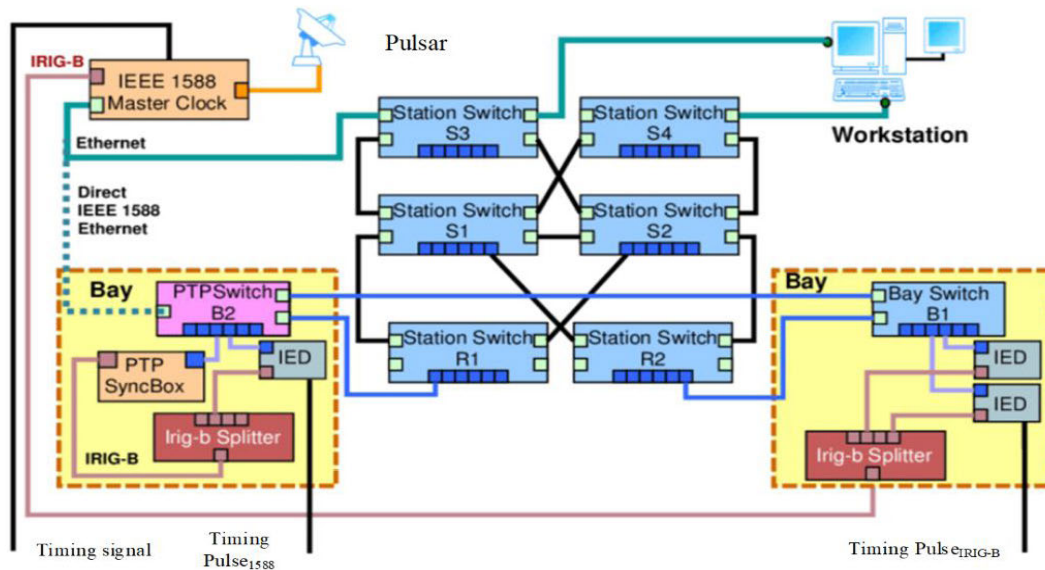

FIGURE 3. Network architecture for the pulsar timing generation subsystem and the PTP standard IEEE 1588.

lower (generated) frequencies in the Intermediate Frequency (IF) range plus perform first-stage signal processing. Note that there are numerous, candidate mature antenna back-end technologies that are available. Noteworthy famous antenna back-end systems existing for different radio telescopes have been examined. These include: the Puerto Rico Ultimate Pulsar Processing Instrument (PUPPI), Mock Spectrometers, Wideband Arecibo Pulsar Processor (WAPP) Correlators, and Galactic Arecibo L-band Feed Array (GALFA) Spectrometers [14]. We utilize a Smart Network ADC Processor (SNAP) to function as the antenna back-end. The SNAP was designed for the Hydrogen Epoch of Reionization Array which is designed by both National Radio Astronomy Observatory and the University of California, Berkeley. The reason for choosing a SNAP board is predicated on its modular design and low cost. In addition, the SNAP meets the target bandwidth, 500 MHz, of the SNAP tailored for NRAO20. As previously stated, pulsar timing signals have high long-term stability, however, their short-term stability is not as precise principally due to noises and interferences from outer space, the atmosphere, and antenna, etc. as well as signal processing errors [15]. Furthermore, the square waveform from the pulse signal processing and extraction subsystem has the same period as the pulsar rotation and, therefore, is not necessarily an integral decimal of a second. To solve these two problems, a pulse signal processor utilizing a local clock with good short-term stability is designed for accurate pulse signal generation through a locking and control module. This double over controlled oscillator (DOXCO) – functioning as a local clock outputs frequency/timing which is controlled via an external voltage (similar to a classic voltage-controlled-oscillator, VCO). This timing signal generator also incorporates a digital to analog converter (DAC), where the resolution is designed to be 100ns. The net result is a timing signal

generator which receives the digital pulse signals from the pulse signal processor and generates the PPS signal which can be directly used in monitoring the local power system device.

Note that the designed time error of the PPS is less than 100ns. However, under real world deployment, the minimum requirement for the time error of the PPS is ± 26 us for a 60Hz power system device. This provides a PBTI prototype design target for the initial time error requirement.

Numerous logistical issues may arise if a PBTI system is deployed at a remote locations, such as at a transmission substation. Of note are determining the proper environment (ambient conditions and location within, again for example, a substation) for pulsar receiver installation, pulsar-based time signal generation and distribution integrated with at-site synchronized timing signals. In such a situation, we advocate the utilization of a time distribution system such as that associated with IEEE 1588.C3. Such a timing distribution system will transmit accurate and synchronized timing signals from the timing signal generation subsystem to remote locations without an installation of a pulsar receiver at each location. This 1588 - Precision Time Protocol (PTP) - protocol of timing signal distribution aligns temporally with the high accuracy, reliability, and compatibility requirements of the PMUs and related measurement devices. Based on timestamps, the PTP boundary clock calculates the time offset from the grandmaster clock and eventually aligns its local time to the grandmaster time. The timing signal generated by the pulsar timing generation subsystem is used as the grandmaster clock for the PTP time distribution system. The PTP server generates PTP messages according to the time generated by the pulsar timing generation subsystem and the PTP standard IEEE 1588 as shown in Fig. 3. As previously stated, PTP-compliant messages are transmitted through an Ethernet-based network to the PTP client at remote

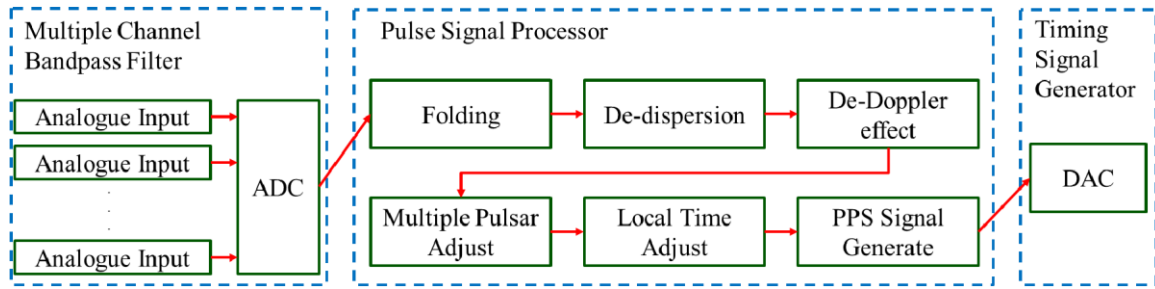

FIGURE 4. The software architecture of the PBTI.

substations, which corrects any time error associated the boundary clock or the slave clock connected to the PTP client. Thus the corrected locally-resident clock is able to provide synchronized and accurate timing signals for local power system measurement and operational devices.

With the above design, the pulsar signals can be finally translated into accurate and stable timing signals to be used by both the local and remote power system devices. With respect to a cost consideration the cost of the radio telescope set up, deploying the PBTIs with the existing radio telescopes and utilize the PTP technology discussed above would be the best solution to provide accurate and stable timing signals to the remote power system devices.

III. THE SOFTWARE ARCHITECTURE OF THE PULSAR BASED TIMING INSTRUMENT

As shown in Fig. 4, the software architecture of the PBTI is given. Six subfunction blocks in the pulse signal processor, i.e., (1) the folding, (2) de-dispersion, (3) de-Doppler effect, (4) multiple pulsar adjust, (5) local time adjust, and (6) the PPS signal generate are shown. Note that the first three subfunction blocks are commonly utilized in standard approaches employed at radio telescopes. Some helpful and open source software can be found in [16]–[18].

The signal isolation and processing is optimized through the use of a multiple channel bandpass filter thereby separating the sampled radio frequency signals into digital signals within the bandwidth. The detailed design for the ADC is given in Fig. 5 which includes an Analog to Digital Converter (ADC), a Polyphase Filter Bank (PFB), a Fast Fourier transform (FFT), and an accumulator. Since the SNAP board utilizes the Matlab Simulink for the FPGA coding all required modules are written using a Matlab Simulink environment. Currently, all the backend parameters are still under design phase. The detailed parameters will be introduced in the future work. Since such signals are usually weak – primarily due to the antenna gain associated with a “realistically sized” telescope, a folding processor is usually necessary to cancel the noise and therefore enhance the pulse signals (increased SNR). The folding requires multiple periods of the pulse signals, hence a moving folding window technology is used to provide the real timing folding function. Note that the moving folding window technology is designed based on both the folding and moving window technologies which is still

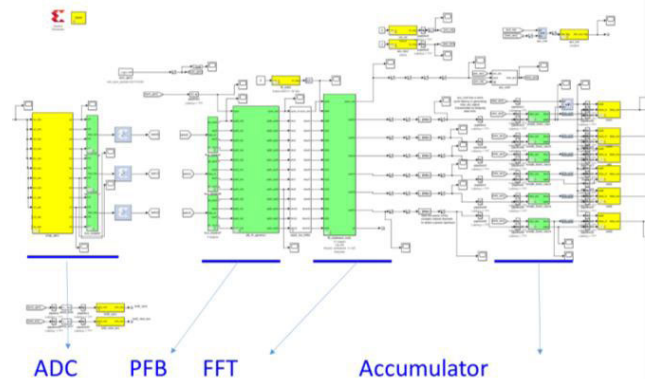

FIGURE 5. ADC design in the SNAP board.

under design and development phase. The time error of the local clock is determined using the moving folding window.

After folding, the pulse signals are de-dispersed to address standard pulse dispersion (high frequencies arriving slightly before the lower frequency signals – both originating from the same pulsar). The incorporation of a simple time shift added to the pulse signals minimizes the temporal dispersive effect. Note that the period of the pulse signal in different frequency is still the same. The time shift is calculated by,

$$\Delta t_{disp} = 4.15 \times 10^6 \times (f_1^{-2} - f_2^{-2}) \times DM, \quad (1)$$

where t_{disp} is the time shift between two observation frequencies, i.e., f and f_2 ; DM is the dispersion measure which is identical for each pulsar. t_{disp} is with unit of milliseconds and frequencies are with MHz [19].

The next sub-function involves correction for Doppler-induced temporal dispersion. Since the radio telescope is not operating in a non-inertial frame of reference, the relative velocities of ground based observatories in the direction of an observed object are different for different locations. In order to normalize the time of arrival (TOA) of pulses, a de-Doppler effect sub-function block is utilized. Note that the relative velocity data can be determined using a pulse signal processor. Scintillation is a well-known phenomenon in astronomy, e.g., twinkling of stars due to scattering in the Earth’s atmosphere, and variability of compact radio sources due to scattering in the ionosphere and the solar wind [20]. Within this sub-function block, the folding period is modified and thus minimizes the probability of a failure to detect a

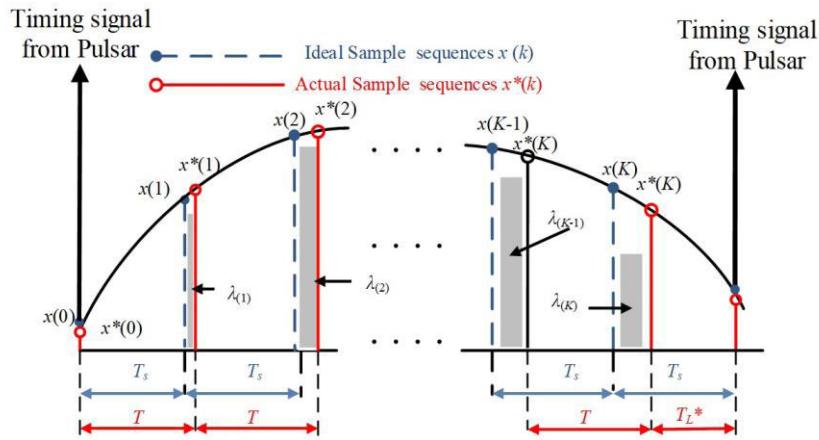

FIGURE 6. Schematic diagram of the sampling time caused by imperfect oscillator.

pulsar signal. In such a situation, in order to have a continuous and stable pulse signal (for the measurement and grid operational devices), the pulse signal processor would change to a backup pulsar if the current observing pulsar has a scintillation or is out of the telescope’s field of view. Thus, a multiple pulsar adjust function is designed to determine whether it is necessary to switch the current pulsar to a backup one. After making a decision to switch pulsars, this sub-function block sends out a trigger signal to the antenna back-end to switch all settings related to the backup pulsar and begin tracking that pulsar. Note that the PBTI can also operate without pulsar switching and even without a pulsar always in view, depending on the stability of the local clock.

As discussed in the hardware architecture section, with the stable and precise short term pulse signals generated by the moving folding window technology, a local clock is utilized to compare the pulse signal and thus generate an error. This error signal is used in a classic first order feedback loop design to discipline the input of the local clock.

Finally, through all the previous sub-function blocks, the pulse signals from the pulsar are stable. The PPS signal generation function block transfers the pulse signal with irregular period into a PPS signal. Due to the local time adjust function and the local clock, the PPS signal generate function block will continue to send a PPS signal to the DAC even in the situation where there is no pulsar signal. However, without pulses being received (decoded) from a pulsar, the error of the local clock will keep increasing. In this case, the PPS signal generated will temporally drift until a situation is reached where an accurate PPS signal cannot be generated. In such an occurrence a simple alarm signal is generated.

IV. POTENTIAL APPLICATIONS OF THE PULSAR BASED TIMING INSTRUMENT

In this section, four potential applications of the pulsar based timing instrument are given and discussed. Since the PBTI is still under design and development phase, we may not be able to claim the PBTI can satisfy all the requirements for those

applications. However, these applications would be the target applications for the proposed PBTI.

A. DETECTION OF GLOBAL NAVIGATION SATELLITE SYSTEM OUTAGES AND CYBER-ATTACKS USING PULSAR-BASED TIMING SOURCE

Global Navigation Satellite System (GNSS) is the root timing source of most networked sensor systems. However, the timing reliability provided by a GNSS is threatened by a variety of terrestrial and space-based factors including system failures, space weather, jamming and spoofing. A GNSS timing source (such as GPS) vulnerability that is receiving increased acknowledgement is that associated with cyber-attacks. It has been demonstrated that such an attack will result in inaccurate timing information for networked sensor systems [21]–[23]. This may lead to serious system operational consequences since synchronized measurement sensors rely on GPS for time synchronization.

B. A PULSAR TIMING BASED SAMPLING INTERVAL CONTROL

Accurate sampling interval control is critical for synchronized measurement devices in power grids since measurement accuracy is directly influenced by waveform sampling control. The use of periodic signals from a pulsar-based timing source to discipline the waveform sampling by triggering the interrupt of the microcontroller in power system devices ensures that the first sample in each second is aligned to the pulsar timing signal. From the second sample to the last sample between adjacent pulsar timing signals, the controller stabilizes the sampling interval. It is envisioned that this sampling interval control method needs to be enhanced to mitigate any sampling time error arising from practical issues such as crystal variation induced frequency drifts and aging of the internal oscillator [24]. Fig. 6 shows the ideal sampling sequence $x(k)$ as well as the practical sampling sequence $x^*(k)$ when the oscillator frequency is drifted (note that λ represents the sampling error and T_L^* is the time interval between the last sampling point in the previous second and the next pulsar timing signal). Such a sampling

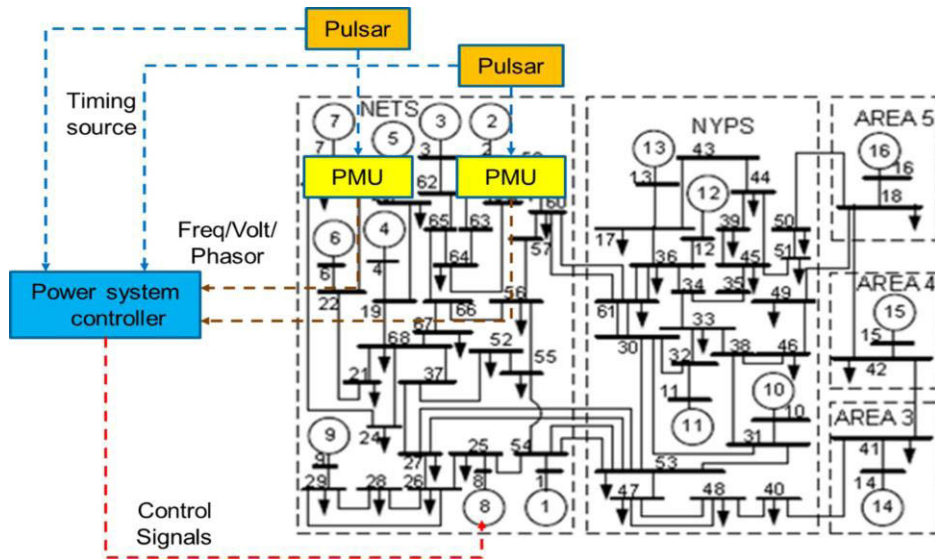

FIGURE 7. Application of the pulsar-based timing source for power system controller.

time error is accumulated to TL^* . To improve the accuracy of sampling interval control, the pulsar timing signals can be also used as a reference to measure the actual performance of the oscillator; thus, the control parameters can be adaptively adjusted in a close loop manner. Moreover, by employing this pulsar synchronization strategy, the sampling error can be cleared by the arrival of a pulse and will therefore not accumulate beyond a period of the pulsar timing signal.

C. INTEGRATION OF PULSAR TIMING TO DEVELOP HYBRID TIMING SOURCES FOR SYNCHRONIZATION RELIABILITY ENHANCEMENT

As previously stated, conventional power grid measurement devices, such as PMUs, rely principally on timing references, such as GPS or network time protocol (NTP) signals, for time synchronization. It is well known that a variety of uncontrollable and unpredictable factors (e.g., atmospheric disturbances, weather changes, GPS signal attacks, and solar activities) may cause GPS receivers inside PMUs to occasionally lose signal, even if their antennas are placed in a location with an unobstructed view of satellites. This situation is exacerbated if defects exist in the GPS signals leading to a situation where PMUs may generate significant errors in the voltage or current measurements, which may further lead to a chain of “malfunctions” of power system control and protection. To address this issue, the pulsar signal can be integrated with the GPS synchronization system. When the performance of the GPS timing signal is unsatisfactory, PMUs will immediately switch to a pulsar timing source mode to improve the reliability of synchronization under GPS holdover conditions.

D. A PULSAR TIMING BASED POWER SYSTEM CONTROLLER

Accurate and synchronized control signals are critical for power system controllers [25], [26]. The measurements

(such as voltage, current, and frequency, etc.) at different locations need to be temporally synchronized prior to signal transmission to power system controllers as control inputs [27]–[29]. In addition, wide-area grid operation controllers require an accurate time source to calculate and compensate for network path induced time delay. Taking advantage of the accurate and clean timing characteristics of pulsar signals, a pulsar timing based power system controller, such as that presented in Fig. 7, may be designed and developed. As shown in Fig. 7, two PMUs receive the timing signals from the PBTI and send the synchrophasors back to the power system controllers. At the same time, the PBTI also provides timing signal to the power system controller for control signal timing. With the accurate timing signals, the power system controller could generate synchronized control signals to the generators. Thus, a completed close loop control can be established by utilizing pulsar based timing sources.

V. POTENTIAL PROBLEMS FOR PULSAR-BASED TIMING SOURCE

There are a variety of potential problems for utilizing the pulsar-based timing source. Five major problems associated with the potential use and deployment of this system in a utility substation are discussed. The first is the cost of radio telescope setup and maintenance which may cost hundreds of thousands dollars. The second one is the SNR around the radio telescope location. Since the pulsar signal is mixed with the noise from the environment, the noise could have influences on the timing signal accuracy. The third one is the continuous timing signal generation since the pulsars may only be observed for hours per day and the pulsar switch module may take time to folding the pulsar signals. There would be a time gap where no pulsar data can be utilized to calibrate the local timer. The fourth one is the pulsar selection. The PBTI requires a stable and highly precise pulsar period

to generate timing signal. Although millisecond pulsar can satisfy the requirements for timing signals, it also requires a large antenna and low SNR for the environment. There are some “canonical” pulsars which have the potentiality to provide stable and highly precise timing signals. The author team would continue working on this topic and try to find out the best pulsar selection in the future. The final one is the PBTi spoofing problems. Similar to the GPS spoofing, there are potential attack to the PBTi. The research team would work on the PBTi attack identification and correction in the future. There are certainly other potential problems existing in the PBTi design and we would update them in our future work.

VI. CONCLUSION

The design and potential utilization of a pulsar based timing instrument has been presented. The software and hardware architectures of the pulsar based timing instrument have been described. In the hardware architecture, the radio telescope, antenna backend, local clock, pulse signal processor, timing signal generator, and timing signal transition network were described in terms of functionality and structure. Meanwhile, in the software architecture, the sub-functions in the pulse signal processor, including folding, de-dispersion, de-Doppler effect, multiple pulsar adjust, local time adjust, and the PPS signal generate, were introduced along with the basic functionality and implementation guidelines presented. Finally, four future applications of the pulsar based timing instrument and the benefits of utilizing the pulsar based timing instrument have been discussed in detail.

REFERENCES

- [1] *IEEE/IEC International Standard—Measuring Relays and Protection Equipment—Part 118-1: Synchrophasor for Power Systems—Measurements*, IEC/IEEE Standard 60255-118-1:2018, Dec. 2018, pp. 1–78.
- [2] Y. Liu, L. Zhan, Y. Zhang, P. N. Markham, D. Zhou, J. Guo, Y. Lei, G. Kou, W. Yao, J. Chai, and Y. Liu, “Wide-area-measurement system development at the distribution level: An FNET/GridEye example,” *IEEE Trans. Power Del.*, vol. 31, no. 2, pp. 721–731, Apr. 2016.
- [3] A. Mujunen, J. Aatrokoski, M. Tornikoski, and J. Tammi, “GPS time disruptions on 26-Jan-2016,” Metsähovi Radio Observatory, Kirkkonummi, Finland, Tech. Rep., 2016.
- [4] B. B. P. Perera, M. E. DeCesar, P. B. Demorest, M. Kerr, L. Lentati, D. J. Nice, S. Osłowski, S. M. Ransom, M. J. Keith, Z. Arzumianian, and M. Bailes, “The international pulsar timing array: Second data release,” *Monthly Notices Roy. Astronomical Soc.*, vol. 490, no. 4, pp. 4666–4687, 2019.
- [5] Z. Arzumianian, A. Brazier, S. Burke-Spolaor, S. Chamberlin, S. Chatterjee, B. Christy, J. M. Cordes, N. J. Cornish, F. Crawford, H. T. Cromartie, and K. Crowter, “The NANOGrav 11-year data set: High-precision timing of 45 millisecond pulsars,” *Astrophysical J. Suppl. Ser.*, vol. 235, no. 2, p. 37, 2018.
- [6] M. Kerr et al., “The parkes pulsar timing array project: Second data release,” 2020, *arXiv:2003.09780*. [Online]. Available: <http://arxiv.org/abs/2003.09780>
- [7] N. Yunes and X. Siemens, “Gravitational-wave tests of general relativity with ground-based detectors and pulsar-timing arrays,” *Living Rev. Relativity*, vol. 16, no. 1, p. 9, Dec. 2013.
- [8] L. M. B. Wintemitz, J. W. Mitchell, M. A. Hassounah, J. E. Valdez, S. R. Price, S. R. Semper, W. H. Yu, P. S. Ray, K. S. Wood, Z. Arzumianian, and K. C. Gendreau, “SEXTANT X-ray pulsar navigation demonstration: Flight system and test results,” in *Proc. IEEE Aerosp. Conf.*, Mar. 2016, pp. 1–11.
- [9] C. Powell and G. Tasinato, “Probing a stationary non-Gaussian background of stochastic gravitational waves with pulsar timing arrays,” *J. Cosmology Astroparticle Phys.*, vol. 2020, no. 1, p. 17, 2020.
- [10] W. Qin, K. K. Boddy, M. Kamionkowski, and L. Dai, “Pulsar-timing arrays, astrometry, and gravitational waves,” *Phys. Rev. D, Part. Fields*, vol. 99, no. 6, Mar. 2019, Art. no. 063002.
- [11] J. M. Cordes and M. A. McLaughlin, “Gravitational waves, extreme astrophysics, and fundamental physics with precision pulsar timing,” 2019, *arXiv:1903.08653*. [Online]. Available: <http://arxiv.org/abs/1903.08653>
- [12] D. R. B. Yardley, G. B. Hobbs, F. A. Jenet, J. P. W. Verbiest, Z. L. Wen, R. N. Manchester, W. A. Coles, W. Van Straten, M. Bailes, N. D. R. Bhat, S. Burke-Spolaor, D. J. Champion, A. W. Hotan, and J. M. Sarkissian, “The sensitivity of the parkes pulsar timing array to individual sources of gravitational waves,” *Monthly Notices Roy. Astronomical Soc.*, vol. 407, no. 1, pp. 669–680, Sep. 2010.
- [13] *Green Bank 20-Meter Telescope*. Accessed: Jun. 2020. [Online]. Available: <https://www.gb.nrao.edu/fgdocs/20m/GB20m.html>
- [14] [Online]. Available: <https://www.naic.edu/puppi-observing/>
- [15] Y. Dong-Shan, G. Yu-Ping, and Z. Shu-Hong, “Ensemble pulsar time scale,” *Chin. Astron. Astrophys.*, vol. 41, no. 3, pp. 430–441, 2017.
- [16] *The DSPSR Project*. Accessed: Jun. 2020. [Online]. Available: <http://dspsr.sourceforge.net/>
- [17] *The PSRCHIVE Project*. Accessed: Jun. 2020. [Online]. Available: <http://psrchive.sourceforge.net/>
- [18] *Breakthrough Listen I/O Methods for Python*. Accessed: Jun. 2020. [Online]. Available: <https://github.com/UCBerkeleySETI/blimpy>
- [19] D. R. Lorimer and M. Kramer, *Handbook of Pulsar Astronomy*, vol. 4. Cambridge, U.K.: Cambridge Univ. Press, 2004.
- [20] R. Narayan, “The physics of pulsar scintillation,” *Philos. Trans. Roy. Soc. London A, Phys. Eng. Sci.*, vol. 341, no. 1660, pp. 151–165, 1992.
- [21] L. Zhan, Y. Liu, W. Yao, J. Zhao, and Y. Liu, “Utilization of chip-scale atomic clock for synchrophasor measurements,” *IEEE Trans. Power Del.*, vol. 31, no. 5, pp. 2299–2300, Oct. 2016.
- [22] W. Yao, D. Zhou, L. Zhan, Y. Liu, Y. Cui, S. You, and Y. Liu, “GPS signal loss in the wide area monitoring system: Prevalence, impact, and solution,” *Electr. Power Syst. Res.*, vol. 147, pp. 254–262, Jun. 2017.
- [23] X. Jiang, J. Zhang, B. J. Harding, J. J. Makela, and A. D. Dominguez-Garcia, “Spoofing GPS receiver clock offset of phasor measurement units,” *IEEE Trans. Power Syst.*, vol. 28, no. 3, pp. 3253–3262, Aug. 2013.
- [24] W. Yao, L. Zhan, Y. Liu, M. J. Till, J. Zhao, L. Wu, Z. Teng, and Y. Liu, “A novel method for phasor measurement unit sampling time error compensation,” *IEEE Trans. Smart Grid*, vol. 9, no. 2, pp. 1063–1072, Mar. 2018.
- [25] F. Bai, X. Wang, Y. Liu, X. Liu, Y. Xiang, and Y. Liu, “Measurement-based frequency dynamic response estimation using geometric template matching and recurrent artificial neural network,” *CSEE J. Power Energy Syst.*, vol. 2, no. 3, pp. 10–18, 2016.
- [26] L. Zhu, H. Liu, Y. Ma, Y. Liu, E. Farantatos, M. Patel, and S. McGuinness, “Adaptive and coordinated oscillation damping control using measurement-driven approach,” in *Proc. Power Syst. Comput. Conf. (PSSC)*, Jun. 2016, pp. 1–7.
- [27] L. Zhu, H. Liu, Z. Pan, Y. Liu, E. Farantatos, M. Patel, S. McGuinness, and N. Bhatt, “Adaptive wide-area damping control using measurement-driven model considering random time delay and data packet loss,” in *Proc. IEEE Power Energy Soc. Gen. Meeting (PESGM)*, Jul. 2016, pp. 1–5.
- [28] F. Bai, Y. Liu, Y. Liu, K. Sun, N. Bhatt, A. Del Rosso, E. Farantatos, and X. Wang, “A measurement-based approach for power system instability early warning,” *Protection Control Mod. Power Syst.*, vol. 1, no. 1, pp. 1–9, Dec. 2016.
- [29] F. Bai, Y. Liu, Y. Liu, and X. Wang, “A simulation-based linearity study of large-scale power systems,” in *Proc. IEEE Power Energy Soc. Gen. Meeting (PESGM)*, Jul. 2016, pp. 1–5.



HE YIN (Member, IEEE) received the B.S. and Ph.D. degrees in electrical and computer engineering from the University of Michigan-Shanghai Jiao Tong University Joint Institute, Shanghai Jiao Tong University, Shanghai, China, in 2012 and 2017, respectively.

He is currently a Postdoctoral Researcher with the Center for Ultra-Wide-Area Resilient Electric Energy Transmission Networks (CURENT), University of Tennessee, Knoxville, TN, USA. His research interests include optimization and decentralized control of microgrid, and phasor measurement unit design.



YILU LIU (Fellow, IEEE) received the B.S. degree from Xi'an Jiaotong University, China, and the M.S. and Ph.D. degrees from The Ohio State University, Columbus, OH, USA, in 1986 and 1989, respectively.

She was a Professor with Virginia Tech. She led the effort to create the North American power grid Frequency Monitoring Network (FNET), Virginia Tech, which is currently operated with UTK and the Oak Ridge National Laboratory (ORNL) as

GridEye. She is currently the Governor's Chair with the University of Tennessee, Knoxville, TN, USA, and ORNL. She is elected as a member of the National Academy of Engineering, in 2016. She is also the Deputy Director of the DOE/NSF-Co-funded Engineering Research Center CURENT. Her current research interests include power system wide-area monitoring and control, large interconnection-level dynamic simulations, electromagnetic transient analysis, and power transformer modeling and diagnosis.



PETER L. FUHR (Senior Member, IEEE) received the B.S. degree in physics and mathematics from Beloit, WI, USA, and the M.S.E. and Ph.D. degrees in electrical engineering from Johns Hopkins University, Baltimore, MD, USA.

He is a Distinguished Scientist with the Oak Ridge National Laboratory serving in the capacity as the Technology Director with the Unmanned Aerial Systems (UAS) Research Laboratory and the Director of Grid Security. He is currently a

Professor of electrical engineering and computer science with the University of Tennessee with an affiliated appointment within the University's Bredesen Center. He has been involved in industrial wireless, sensors, and secure systems, as a NASA Space Optical Physicist, a University Professor, and a Serial Entrepreneur. He has been a Researcher with the Department of Energy National Laboratory. He has authored or delivered hundreds of technical journal and conference publications/presentations. Segments of his research activities are featured in the SPIE Milestone Series on Fiber Optics.

Dr. Fuhr received the Presidential Award for Excellence in Research for his pioneering work in networked sensor systems for structures.



MARISSA MORALES RODRIGUEZ (Member, IEEE) was born in San Juan, Puerto Rico. She received the B.S. and M.S. degrees from the Department of Chemistry, University of Puerto Rico at Mayagüez, in 2006 and 2008, respectively, and the Ph.D. degree in energy science and engineering (with entrepreneurship track) from the Bredesen Center for Interdisciplinary Research and Graduate Education, University of Tennessee, Knoxville, TN, USA, in 2017.

She is currently a Research Scientist with the Oak Ridge National Laboratory, Oak Ridge, TN, USA. She is the principal investigator and manages projects related to the research and development of cyber-physical sensors with applications in the energy, defense, environmental and manufacturing industries. She is the author/coauthor of over ten publications and two patents issued. Her research interests include sensors development for controls and security of smart grid to increase resilience and reliability for energy delivery systems by augmenting visualization of electrical distribution systems, including integration of multiple traditional sensing parameters as well as state of the art optical sensors, printed electronics, and their integration to decentralized data architectures for data security and automation of grid edge devices in distribution systems.

MARGARET MORGANTI (Associate Member, IEEE) received the M.S. degree in intelligence studies with a focus on cybersecurity from Mercyhurst University.

He was a Graduate Intern with FireEye, where he worked as a Threat Intelligence Analyst with the iSight Cyber-Physical Team. He is currently a Technical Staff Member with the Power and Energy Systems Team, Oak Ridge National Laboratory, focusing on electric grid cybersecurity and resilience research.

WILLIAM MONDAY received the B.S. degree from Tennessee Technological University, Cookeville, Tennessee, USA, and the M.A. degree in national security affairs and strategic studies from the U.S. Naval Postgraduate School, Monterey, CA, USA. His postgraduate work focused on the potential of unconventional attacks on our nation's critical infrastructure and resources potentially using weapons of mass destruction. He holds a Remote Pilot Certificate with a small unmanned aerial systems (UAS) rating.

He is currently a Project Manager and a Technical Professional with the Data System Sciences and Engineering Group, which is a part of the Computing and Computational Sciences Directorate, Oak Ridge National Laboratory. He is a member of the ORNL Field Intelligence Element for national security special projects work where he supports the dynamic needs of numerous national security-related programs and projects. He has more than 30-years of professional experience and involvement with security operations, to include flight operations, together with worldwide intelligence, surveillance, and reconnaissance operations that supported both U.S. and allied forces in addition to the wider U.S. intelligence community. His most current, primary efforts are focused upon providing direct operational support to ongoing and proposed national security efforts to increase the resilience and security of our nation's infrastructure. These efforts are far ranging and span a wide gambit of classified and sensitive research work. He served as a Naval Officer and was assigned to various fleet and joint tours of duty serving in global combat operations that also included sea, land, and air operations as a qualified naval air crewman. Some of his prominent duties included collection and analysis; mission planning, imagery, and intelligence; and targeting.

JASON RICHARDS received the B.S. degree in interdisciplinary studies from King University and the A.A.S. degree in media technologies from the Pellissippi State Community College.

He is currently a Technical Professional with the RF Communications and Intelligent Systems Group. He provides operational and logistical support for numerous projects within the Electrical and Electronics Systems Research Division. He is currently working on multiple projects involving the safety and security of the nation's power grid, particle detection and analysis with remote sensors for the United States Forest Service, and the use of unmanned aerial systems for utility inspections.



STERLING SEAN ROOKE received the Ph.D. degree in engineering from the University of Maryland College Park. He was an Entrepreneur with X8 LLC and Brixon Inc., as they advance cyberspace technologies including machine learning informed industrial controls. He was a Reserve Military Officer with the U.S. Government and the Air Force in the areas of cyber and technology matters. He was an Active Duty Information Warfare Officer with the United States Navy where he

was the command SBIR lead and assigned to IARPA. He was a Civilian, focused on optics, wireless, and electromechanical packaging concerns. He was the Communications Division Director of the ISA. He is currently a Researcher with the Electrical Engineering Department, University of Tennessee, Knoxville, TN, USA. His research interests include polymer chemistry and biotechnology. He was an Instrumentation Measurement Chapter Chair of the IEEE.

...